



# FICHA TÉCNICA



## S80SOL

Marca: **QLIGHT**

Qlight innovación en alarmas y señales para mejorar la eficiencia y la seguridad laboral.

**Qlight**



- Applicable in road construction sites with a limited power supply
- Applicable on vehicles that require a warning light at night
- Can be used to display vehicle position in dark residential parking areas



S80SOL

## SOL solar light model does not require external power supply or wiring!

### Features High Energy Efficiency and Longevity

SOL Solar light models can be used in environmental conditions where power supply is limited or wiring is difficult.

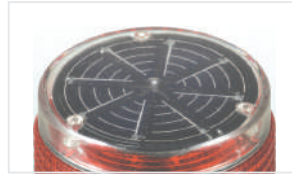

### Features High Energy Efficiency and Longevity

Qlight's solar rechargeable signal lights have a special design that mounts the solar panels inside a structure that minimizes adverse effects such as dust and moisture. This improves the efficiency and extends the lifetime of the product.

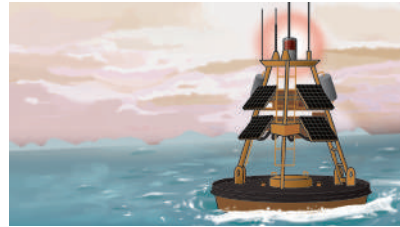

High-tide maritime surveillance systems



Low-speed night vehicle operation



### Common Specifications(S80SOL/ S100SOL/ S125SOL)

- Solar rechargeable LED flashing signal light that does not require an external power supply or wiring
- Built-in Darkness Detection System that automatically begins to operate when darkness is detected
- Fully enclosed structure that can withstand storm and severe dust environments (IP54)
- Prevents discharge using a built-in power switch
- Flashing Rate : 60-80 flashes/min
- Materials : Lens-AS, Body-ABS, Reflector-Heat resistant ABS
- Ambient operating temperature : -25°C to +50°C
- Protection rating : IP54
- Certificates : CE Compliant



### S80SOL Ø80mm Solar Rechargeable LED Flashing Signal Light

- 80mm Compact model
- A single charge (8 hours) serves up to 30 hours of continuous operation

Model number	Battery Voltage	Battery Capacity	Continuous operating time with no charge	Certificates	Weight	Color Options
S80SOL	2.4V	0.77Ah	30Hr	CE	0.27kg	<ul style="list-style-type: none"> <li>• R-Red</li> <li>• A-Amber</li> </ul>



Warning/Signal/Stackable



Signal & Electric Horn/ Speakers



Vessels and Heavy-Duty Equipment



Explosion Proof



Warning Light Bar



Aviation Obstruction Lights



Signal Tower Lights



USB/ETN Signal Tower Lights



Electric Horn/ Speakers



Industrial LED Lights

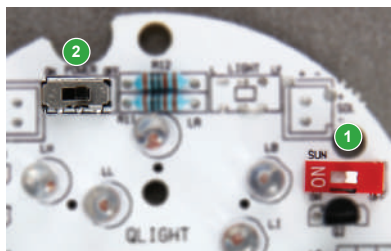

- 1 Sun Switch**  
Automatically turns on the light when darkness is detected.  
Factory default is set to OFF.
- 2 Power Switch**  
ON/OFF power switch that prevents discharge prior to use.  
Factory default is set to OFF.



**S100SOL**

**Technical Diagram** (Units : mm)

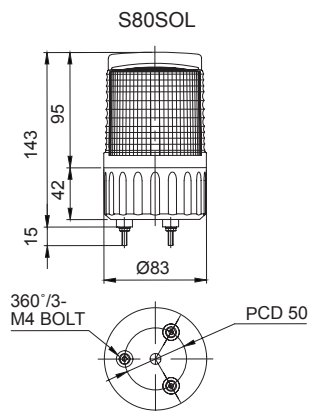

**S100SOL** Ø100mm Solar Rechargeable LED Flashing Signal Light

- Ø100mm model for general purpose
- 40 hours operation continuously by 1 time recharge(8 hours)

Model number	Battery Voltage	Battery Capacity	Continuous operating time with no charge	Certificates	Weight	Color Options
S100SOL	2.4V	0.77Ah	40Hr	CE	0.41kg	<ul style="list-style-type: none"> <li>• R-Red</li> <li>• A-Amber</li> </ul>

**Technical Diagram** (Units : mm)

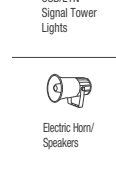
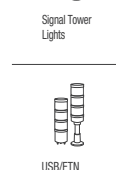
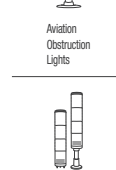
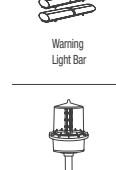
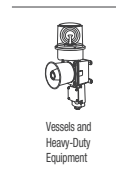
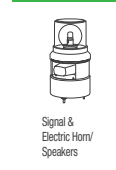
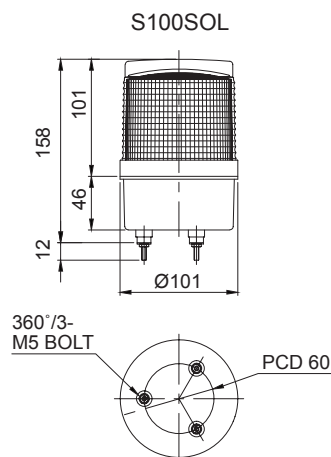



S125SOL



### Technical Diagram

(Units : mm)



### S125SOL Ø125mm Solar Rechargeable LED Flashing Signal Light

- Ø125mm standard item
- 50 hours of continuous operation from 1 time recharge(8 hours)

Model number	Battery Voltage	Battery Capacity	Continuous operating time with no charge	Certificates	Weight	Color Options
S125SOL	2.4V	0.70Ah	50Hr	CE	0.51kg	<ul style="list-style-type: none"> <li>• R-Red</li> <li>• A-Amber</li> </ul>



### Technical Diagram

(Units : mm)

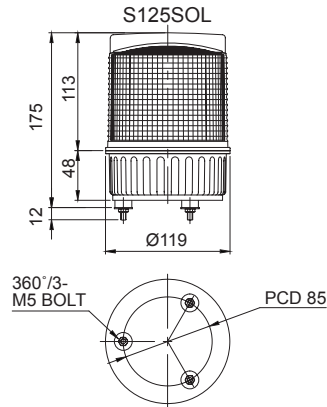

### Accessories

- Magnetic mounting bracket
- Wall mount bracket options : Bracket structure allows for threading through the bracket hole or into the wall mount

- S80SOL



Wall Mount Bracket  
TWS80



Wall Mount Bracket  
TWA80

- S100SOL/ S125SOL



Wall Mount Bracket  
SWP125



Wall Mount Bracket  
SWM125



### Ordering Specification

<b>S80SOL</b>	<b>R</b>
[Model number]	[Color]
<ul style="list-style-type: none"> <li>• S80SOL</li> <li>• S100SOL</li> <li>• S125SOL</li> </ul>	<ul style="list-style-type: none"> <li>• R-Red</li> <li>• A-Amber</li> </ul>



Warning/  
Signal/  
Stackable



Signal &  
Electric Horn/  
Speakers



Vessels and  
Heavy-Duty  
Equipment



Explosion  
Proof



Warning  
Light Bar



Aviation  
Obstruction  
Lights



Signal Tower  
Lights



USB/ETN  
Signal Tower  
Lights



Electric Horn/  
Speakers



Industrial  
LED Lights